

 Join Whatsapp

www.freejobalert.com
Free Job Alert
.com

 Download App

MHT CET 2023
Question Paper
Shift 1 12th
May(Physics)



Join Whatsapp

www.freejobalert.com
Free Job Alert
.com



Download App

Q1. A uniform string is vibrating with a fundamental frequency ' n '. If radius and length of string both are doubled keeping tension constant then the new frequency of vibration is:

- (A) $2n$
- (B) $3n$
- (C) $n/4$
- (D) $n/3$

Q2. Let γ_1 be the ratio of molar specific heat at constant pressure and molar specific heat at constant volume of a monoatomic gas and γ_2 the similar ratio of diatomic gas. Considering the diatomic gas molecule as a rigid rotator, the ratio γ_2/γ_1 is:

- (A) $37/21$
- (B) $27/35$
- (C) $21/25$
- (D) $35/27$

Q3. A railway track is banked for a speed ' v ' by elevating outer rail by a height ' h ' above the inner rail. The distance between two rails is ' d ' then the radius of curvature of track is (g = gravitational acceleration):

- (A) v^2d / gh
- (B) $2v^2 / gdh$
- (C) $gd / 2v^2h$
- (D) $v^2 / 2ghd$

Q4. In the given capacitive network the resultant capacitance between point A and B is:

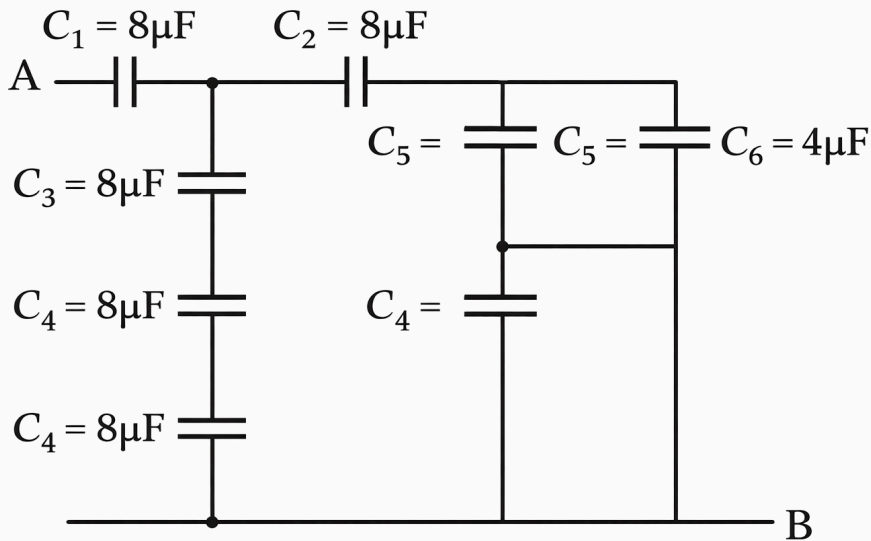

- (A) $8 \mu\text{F}$
- (B) $4 \mu\text{F}$
- (C) $2 \mu\text{F}$
- (D) $16 \mu\text{F}$

Q5. In Young's double slit experiment the intensities at two points, for the path difference $\lambda/4$ and $\lambda/3$ ($\lambda =$ wavelength of light used) are I_1 and I_2 respectively. If I_0 denotes the intensity produced by each one of the individual slits then $(I_1 + I_2)/I_0$ is equal to ($\cos 60^\circ = 0.5$, $\cos 45^\circ = 1/\sqrt{2}$):

- (A) 1
- (B) 2
- (C) 3
- (D) 4

Q6. A simple pendulum performs simple harmonic motion about $x=0$ with an amplitude 'a' and time period 'T'. The speed of the pendulum at $x = a/2$ is:



Join Whatsapp

www.freejobalert.com
Free Job Alert
.com



Download App

- (A) $\pi a / T$
- (B) $3\pi^2 a / T$
- (C) $\pi a\sqrt{3} / T$
- (D) $\pi a\sqrt{3} / 2$

Q7. The molar specific heat of an ideal gas at constant pressure and constant volume is C_p and C_v respectively. If R is universal gas constant and $\gamma = C_p/C_v$ then $C_v =$

- (A) $(1 - \gamma) / (1 + \gamma)$
- (B) $(1 + \gamma) / (1 - \gamma)$
- (C) $(\gamma - 1) / R$
- (D) $R / (\gamma - 1)$

Q8. Resistance of a potentiometer wire is $2 \Omega/m$. A cell of e.m.f. $1.5 V$ balances at 300 cm . The current through the wire is:

- (A) 2.5 mA
- (B) 7.5 mA
- (C) 250 mA
- (D) 750 mA

Q9. A, B and C are three parallel conductors of equal lengths and carry currents I , I and $2I$ respectively as shown in figure. Distance AB and BC is same as 'd'. If F_1 is the force exerted by B on A and F_2 is the force exerted by C on A, then:

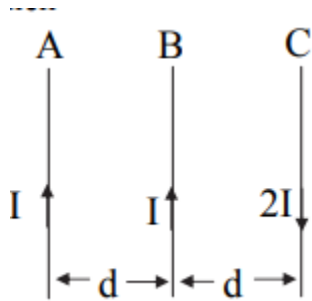

- (A) $F_1 = F_2$
- (B) $F_1 = -F_2$
- (C) $F_1 = 2F_2$
- (D) $F_1 = 1/2 F_2$

Q10. Two electric dipoles of moment P and $27P$ are placed on a line with their centres 24 cm apart. Their dipole moments are in opposite direction. At which point the electric field will be zero between the dipoles from the centre of dipole of moment P ?

- (A) 6 cm
- (B) 8 cm
- (C) 10 cm
- (D) 12 cm

Q11. Converging or diverging ability of a lens or mirror is called:

- (A) focal power
- (B) focal length
- (C) magnifying power

(D) linear magnification

Q12. The following logic gate combination is equivalent to:

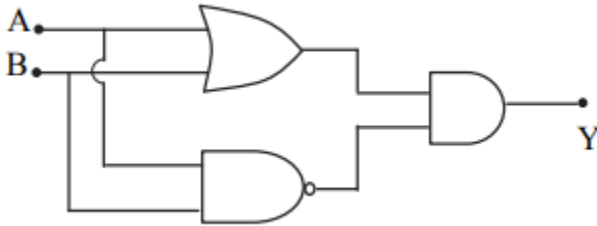

(A) NAND gate

(B) OR gate

(C) XOR gate

(D) NOT gate

Q13. Radiations of two photons having energies twice and five times the work function of metal are incident successively on metal surface. The ratio of the maximum velocity of photo electrons emitted in the two cases will be:

(A) 1:1

(B) 1:2

(C) 1:3

(D) 1:4

Q14. Time period of simple pendulum on earth's surface is 'T'. Its time period becomes 'xT' when taken to a height R (equal to earth's radius) above the earth's surface. Then the value of 'x' will be:

(A) 4

(B) 2

(C) 1/2

(D) 1/4

Q15. Consider a soap film on a rectangular frame of wire of area $3 \times 3 \text{ cm}^2$. If the area of the soap film is increased to $5 \times 5 \text{ cm}^2$ the work done in the process will be (surface tension of soap solution is $2.5 \times 10^{-2} \text{ N/m}$):

- (A) $9 \times 10^{-6} \text{ J}$
- (B) $16 \times 10^{-6} \text{ J}$
- (C) $40 \times 10^{-6} \text{ J}$
- (D) $80 \times 10^{-6} \text{ J}$

Q16. In Lyman series, series limit of wavelength is λ_1 . The wavelength of first line of Lyman series is λ_2 and in Balmer series, the series limit of wavelength is λ_3 . Then the relation between λ_1 , λ_2 and λ_3 is:

- (A) $\lambda_1 = \lambda_2 + \lambda_3$
- (B) $\lambda_2 = \lambda_1 + \lambda_3$
- (C) $1/\lambda_1 = 1/\lambda_2 - 1/\lambda_3$
- (D) $1/\lambda_1 - 1/\lambda_2 = 1/\lambda_3$

Q17. The magnetic moment of a current (I) carrying circular coil of radius ' r ' and number of turns ' n ' depends on:

- (A) n only
- (B) I only
- (C) r only
- (D) n , I and r



Join Whatsapp

www.freejobalert.com
Free Job Alert
.com



Download App

Q18. A spherical drop of liquid splits into 1000 identical spherical drops. If ' E_1 ' is the surface energy of the original drop and ' E_2 ' is the total surface energy of the resulting drops, then $E_1/E_2 = x/10$. Then value of ' x ' is:

- (A) 9
- (B) 7
- (C) 3
- (D) 1

Q19. The displacement of two sinusoidal waves is given by the equation $y_1 = 8 \sin(20x - 30t)$ and $y_2 = 8 \sin(25x - 40t)$. Then the phase difference between the waves after time $t = 2\text{ s}$ and distance $x = 5\text{ cm}$ will be:

- (A) 2 radian
- (B) 3 radian
- (C) 4 radian
- (D) 5 radian

Q20. I_1 is the moment of inertia of a circular disc about an axis passing through its centre and perpendicular to the plane of disc. I_2 is its moment of inertia about an axis AB perpendicular to plane and parallel to axis CM at a distance $2R/3$ from centre. The ratio of I_1 and I_2 is $x:9$. The value

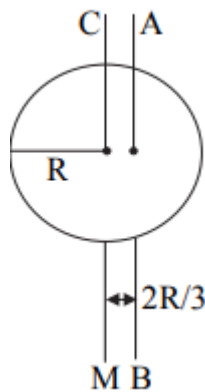

of ' x ' is ($R =$ radius of the disc):

- (A) 9
- (B) 12
- (C) 15
- (D) 17

Q21. The equivalent capacity between terminal A and B is:

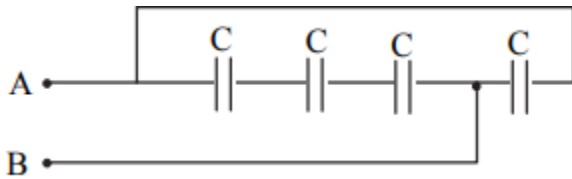

- (A) $C/4$
- (B) $3C/4$
- (C) $4C$
- (D) $4C/3$

Q22. Two similar coils each of radius R are lying concentrically with their planes at right angles to each other. The current flowing in them are I and $2I$. The resultant magnetic field of induction at the centre will be (μ_0 = Permeability of vacuum):

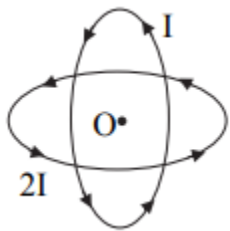

- (A) $\mu_0 I / 2R$
- (B) $\mu_0 I / R$
- (C) $3\mu_0 I / 2R$
- (D) $\sqrt{5}\mu_0 I / 2R$

Q23. The logic gate combination circuit shown in the figure performs the logic function of:

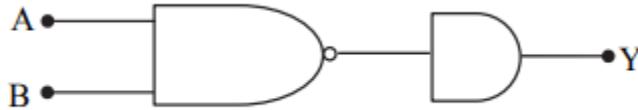

- (A) AND gate
- (B) OR gate
- (C) NAND gate
- (D) XOR gate

Q24. Two sounding sources send waves at certain temperature in air of wavelength 50 cm and 50.5 cm respectively. The frequency of sources differ by 6 Hz. The velocity of sound in air at same temperature is:

- (A) 300 m/s
- (B) 303 m/s
- (C) 313 m/s
- (D) 330 m/s

Q25. In the given circuit, r.m.s. value of current through the resistor R is:

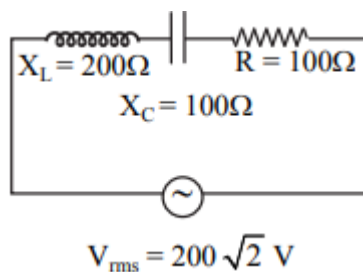

- (A) 2 A
- (B) 0.5 A
- (C) 20 A



Join Whatsapp

www.freejobalert.com
Free Job Alert
.com



Download App

(D) $2\sqrt{2}$ A

Q26. A particle of mass 'm' moving east ward with a speed 'v' collides with another particle of same mass moving north-ward with same speed 'v'. The two particles coalesce after collision. The new particle of mass '2m' will move in north east direction with a speed:

(A) V

(B) 2V

(C) V/2

(D) $V/\sqrt{2}$

Q27. The height at which the weight of the body becomes (1/9)th its weight on the surface of earth is (R = radius of earth):

(A) 8R

(B) 4 R

(C) 3 R

(D) 2 R

Q28. A single turn current loop in the shape of a right angle triangle with side 5 cm, 12 cm, 13 cm is carrying a current of 2A. The loop is in a uniform magnetic field of magnitude 0.75 T whose direction is parallel to the current in the 13 cm side of the loop. The magnitude of the magnetic force on the 5 cm side will be x/130 N. The value of 'x' is:

(A) 4

(B) 9

(C) 12

(D) 15



Join Whatsapp

www.freejobalert.com
Free Job Alert
.com



Download App

Q29. 41 tuning forks are arranged in increasing order of frequency such that each produces 5 beats/second with next tuning fork. If frequency of last tuning fork is double that of frequency of first fork, then frequency of first and last fork is:

- (A) 400, 200 Hz
- (B) 100, 200 Hz
- (C) 200, 400 Hz
- (D) 205, 410 Hz

Q30. In two separate setups for Biprism experiment using same wavelength, fringes of equal width are obtained. If ratio of slit separation is 2:3 then the ratio of the distance between the slit and screen in the two setups is:

- (A) 2:3
- (B) 1:2
- (C) 4:9
- (D) 9:4

Q31. A composite slab consists of two materials having coefficient of thermal conductivity K and $2K$, thickness x and $4x$ respectively. The temperature of the two outer surfaces are T_2 and T_1 ($T_2 > T_1$). The rate of heat transfer through the slab in steady state is $[A(T_2 - T_1)K / x] * f$, where 'f' is equal to:

- (A) 1
- (B) 2/3
- (C) 1/2
- (D) 1/3

Q32. A black sphere has radius 'R' whose rate of radiation is 'E' at temperature 'T'. If radius is made $R/3$ and temperature '3T', the rate of radiation will be:

- (A) E
- (B) 3E
- (C) 6E
- (D) 9E

Q33. The potential on the plates of capacitor are +20V and -20V. The charge on the plate is 40C. The capacitance of the capacitor is:

- (A) 2F
- (B) 1F
- (C) 4F
- (D) 0.5 F

Q34. A thin uniform circular disc of mass 'M' and radius 'R' is rotating with angular velocity 'w'. Another disc of same radius but of mass (M/2) is placed gently on the first disc co-axially. The new angular velocity will be:

- (A) $\frac{2}{3} w$
- (B) $\frac{4}{5} w$
- (C) $\frac{5}{4} w$
- (D) $\frac{3}{2} w$



Join Whatsapp

www.freejobalert.com
Free Job Alert
.com



Download App

Q35. A gas at normal temperature is suddenly compressed to one-fourth of its original volume. If $C_p/C_v = \gamma = 1.5$, then the increase in its temperature is:

- (A) 273 K
- (B) 373 K
- (C) 473 K
- (D) 573 K

Q36. When light of wavelength λ is incident on a photosensitive surface the stopping potential is 'V'. When light of wavelength 3λ is incident, the stopping potential is $V/6$. Then the threshold wavelength for the surface is:

- (A) 2λ
- (B) 3λ
- (C) 4λ
- (D) 5λ

Q37. One of the necessary conditions for total internal reflection to take place is (i = angle of incidence, i_c = critical angle):

- (A) $i < i_c$
- (B) $i = i_c$
- (C) $i = \pi/2$
- (D) $i > i_c$



Join Whatsapp

www.freejobalert.com
Free Job Alert
.com



Download App

Q38. In the given circuit, if $di/dt = -1$ A/s then the value of $(V_A - V_B)$ at this instance will be:

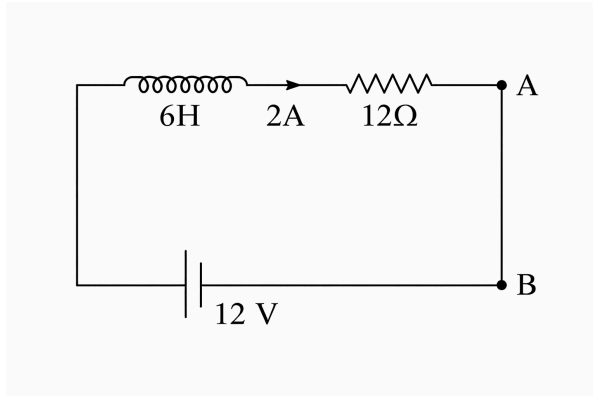

- (A) 30 V
- (B) 24 V
- (C) 18 V
- (D) 9 V

Q39. An inductor of 0.5 mH, a capacitor of 20 μ F and a resistance of 20 Ω are connected in series with a 220 V a.c. source. If the current is in phase with the e.m.f. the maximum current in the circuit is \sqrt{x} A. The value of 'x' is:

- (A) 44
- (B) 82
- (C) 146
- (D) 242

Q40. The wavelength of radiation emitted is λ_0 when an electron jumps from the second excited state to the first excited state of hydrogen atom. If the electron jumps from the third excited state to the second orbit, the wavelength will be $20/x * \lambda_0$. The value of x is:

- (A) 3
- (B) 9



Join Whatsapp

www.freejobalert.com
Free Job Alert
.com



Download App

(C) 13

(D) 27

Q41. Two particles having mass 'M' and 'm' are moving in a circular path with radius 'R' and 'r' respectively. The time period for both is same. The ratio of angular velocity of the first to the second will be:

(A) 1:1

(B) 1:2

(C) 2:3

(D) 3:4

Q42. The excess pressure inside a first spherical drop of water is three times that of second spherical drop. Then the ratio of mass of first spherical drop to second is:

(A) 1:3

(B) 1:6

(C) 1:9

(D) 1:27

Q43. When forward bias is applied to a p-n junction, then what happens to the potential barrier (V_B) and the width (X) of the depletion region?:

(A) V_B increase, X decreases

(B) V_B decreases, X increase

(C) V_B increase, X increase

(D) V_B decreases, X decreases

Q44. Two inductors of 60 mH each are joined in parallel. The current passing through this combination is 2.2 A. The energy stored in this combination in joule is:

- (A) 0.0333
- (B) 0.0667
- (C) 0.0726
- (D) 0.0984

Q45. A beam of light is incident on a glass plate at an angle of 60° . The reflected ray is polarized. If angle of incidence is 45° then angle of refraction is:

- (A) $\sin^{-1}(1 / \sqrt{6})$
- (B) $\sin^{-1}(1 / \sqrt{3})$
- (C) $\sin^{-1}(\sqrt{3/2})$
- (D) $\cos^{-1}(1 / \sqrt{2})$

Q46. Consider a light planet revolving around a massive star in a circular orbit of radius 'r' with time period 'T'. If the gravitational force is proportional to $r^{-7/2}$ then T^2 is proportional to:

- (A) $r(9/2)$
- (B) $r(7/2)$
- (C) $r(5/2)$
- (D) $r(3/2)$

Q47. A potentiometer wire has length of 5 m and resistance of 16Ω . The driving cell has an e.m.f. of 5V and internal resistance 4Ω . When two cells of 1.3V and 1.1V assist each other and then oppose each other, the balancing lengths are:

- (A) 3 m, 0.25 m
- (B) 0.25 m, 3 m
- (C) 2.5 m, 0.3 m
- (D) 0.3 m, 2.5 m

Q48. Four massless springs whose force constants are $2K$, $2K$, K and $2K$ respectively are attached to a mass M . If mass M is displaced horizontally, the frequency of the oscillating system is:

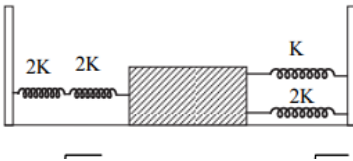

- (A) $\frac{1}{2\pi} \sqrt{K / 4M}$
- (B) $\frac{1}{2\pi} \sqrt{4K / M}$
- (C) $\frac{1}{2\pi} \sqrt{K / 7M}$
- (D) $\frac{1}{2\pi} \sqrt{7K / M}$

Q49. About black body radiation, which of the following is the wrong statement?:

- (A) For all wavelengths, intensity is same.
- (B) For shorter wavelengths, intensity is more.
- (C) For longer wavelengths, intensity is less.
- (D) All wavelengths are emitted by a black body.

Q50. Two coils have a mutual inductance of 0.004 H. The current changes in the first coil as $I = I_0 \sin \omega t$, where $I_0 = 10$ A and $\omega = 50 \pi$ rad/s. The maximum value of e.m.f. in the second coil in volt is:

- (A) 5π
- (B) 4π
- (C) 2.5π
- (D) 2π